

# Instrucțiuni de montaj

6-8 metri

9-10 metri

11-12 metri

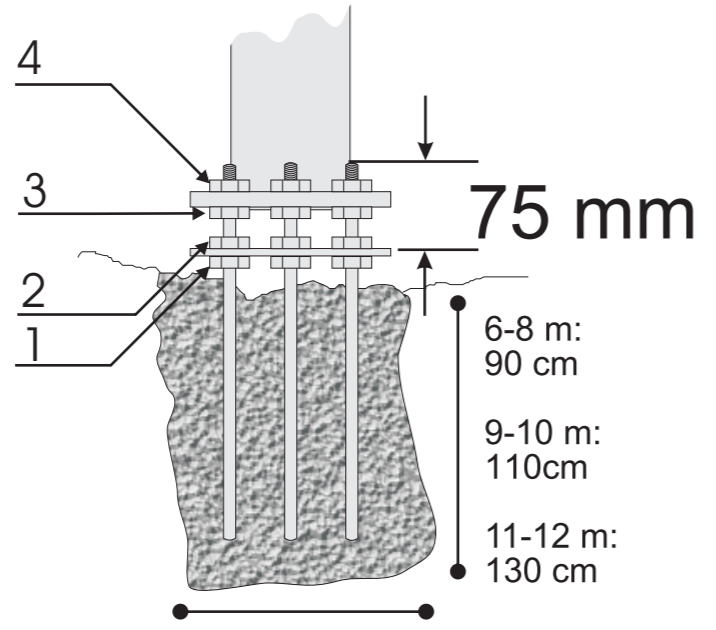
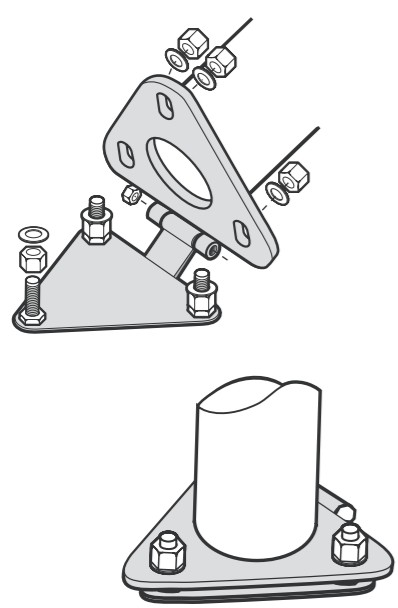
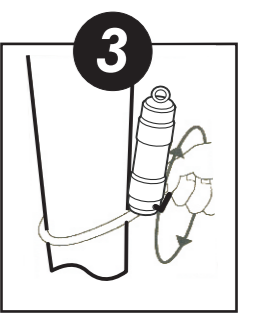
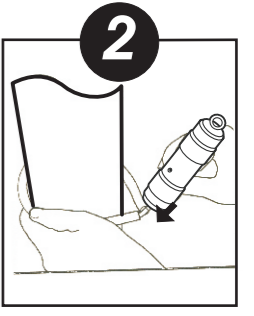
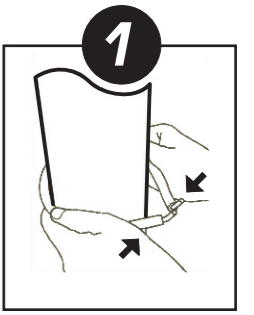
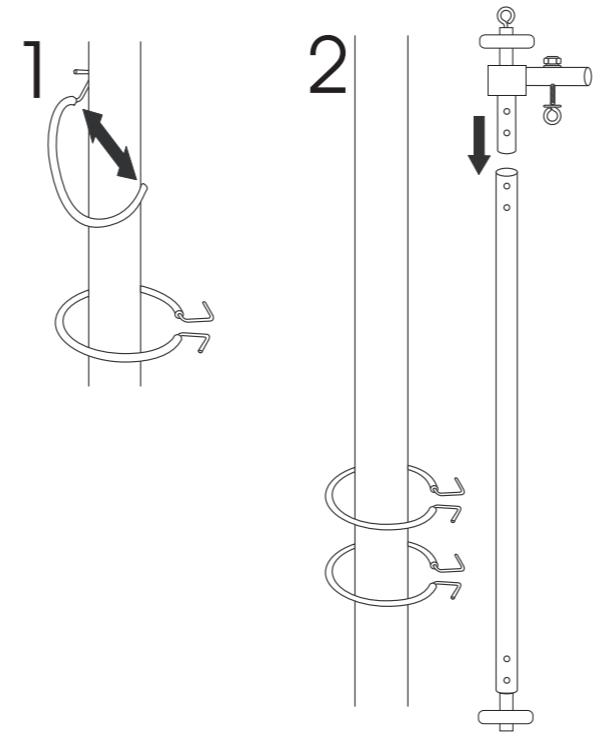
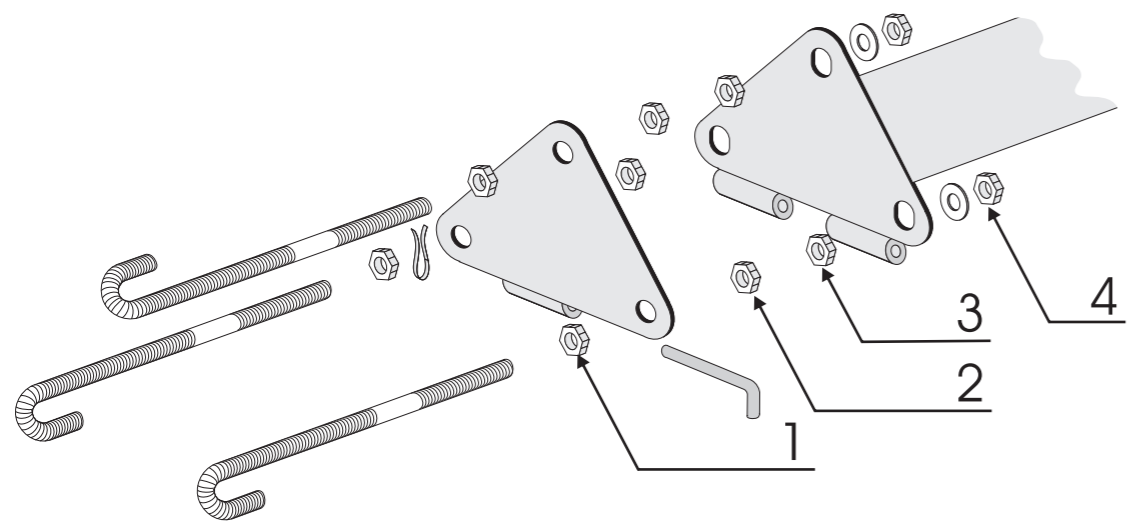
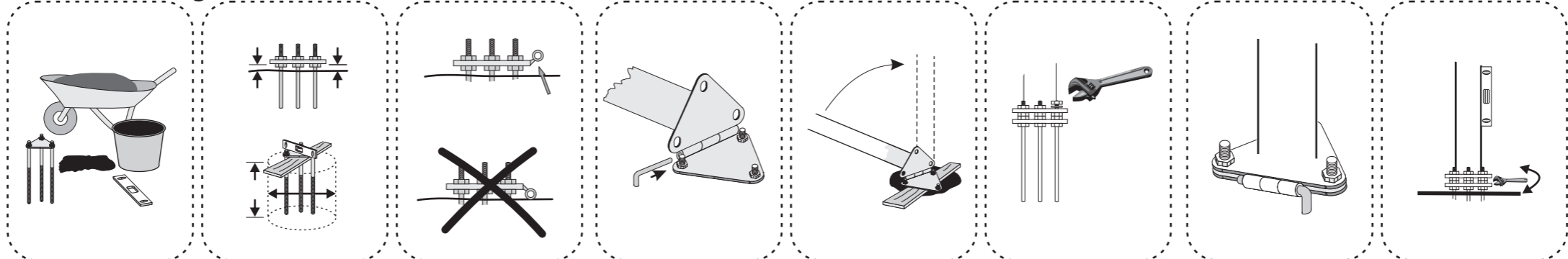

6-8 m: 50x50 cm  
 9-10 m: 60x60 cm  
 11-12 m: 70x70 cm

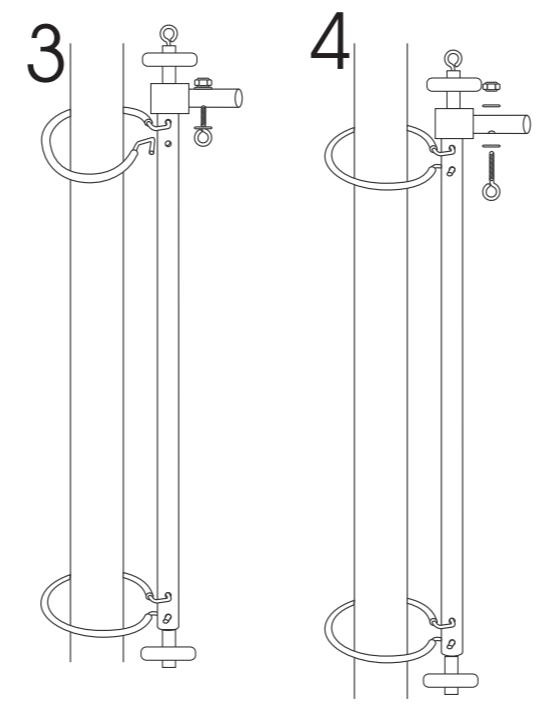

Max 1.5m

Max 1m



PENTRU ALINIAREA GĂURILOR SE URMĂREȘTE SEMNUL AFLAT PE SEGMENTUL SUPERIOR

STIFT FILETAT M6x10

Sistem de imbinare între segmente

