

Caracteristici tehnice

6-8 metri

9-10 metri

11-12 metri

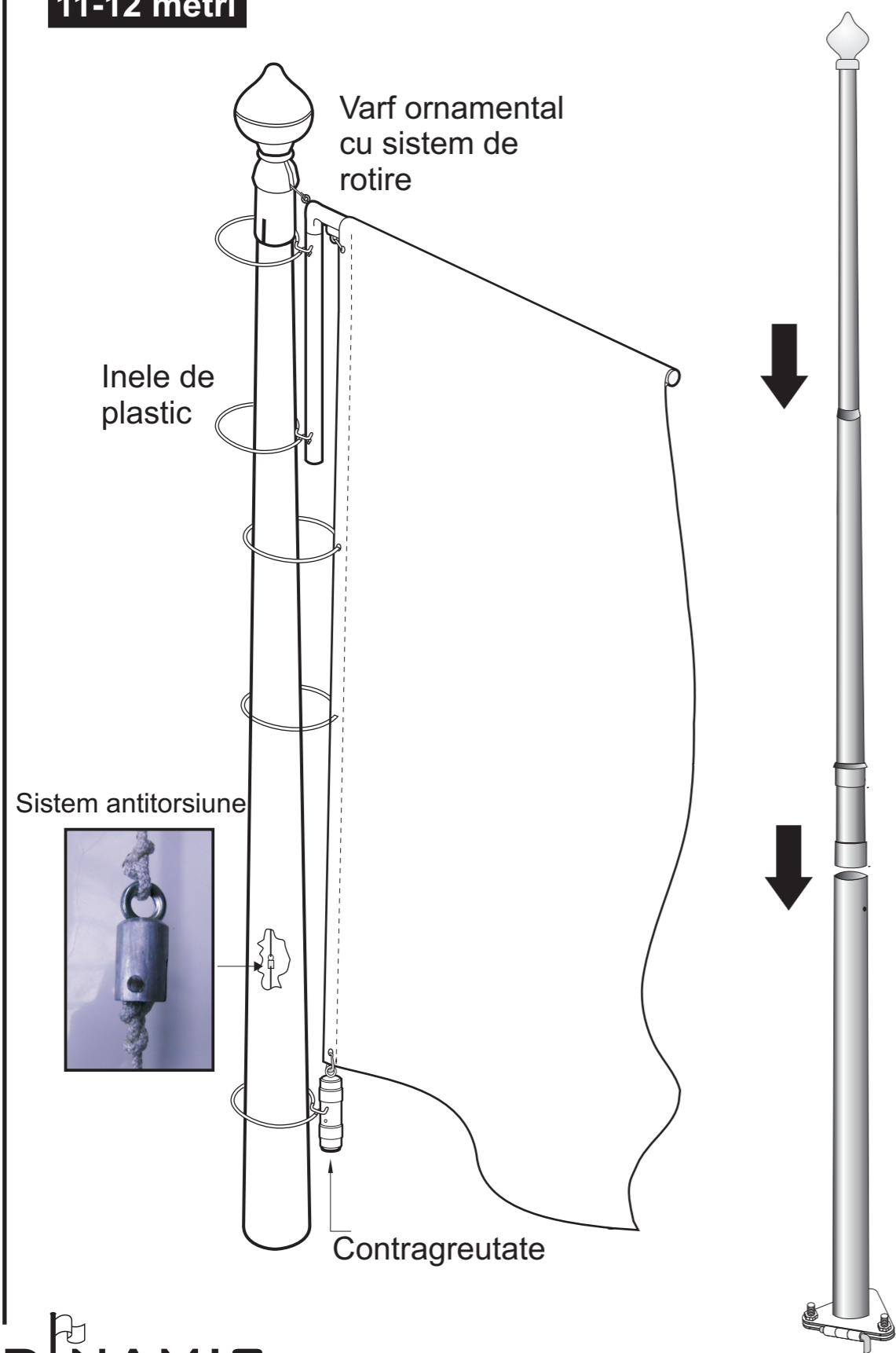

Sistem de imbinare
intre segmente

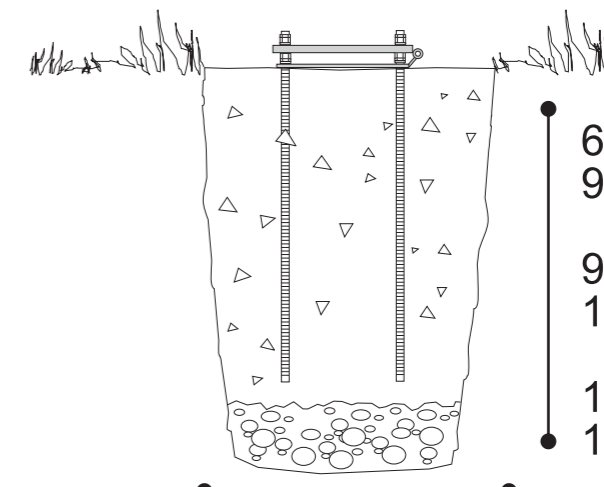
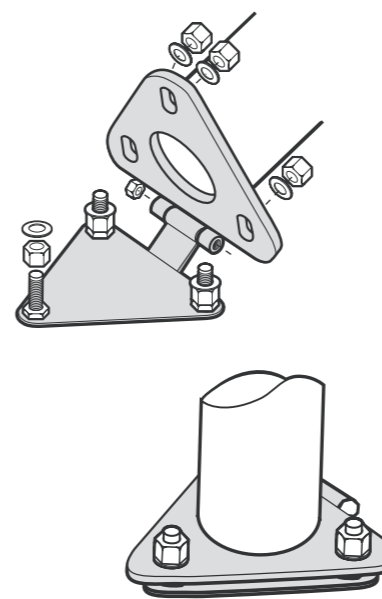
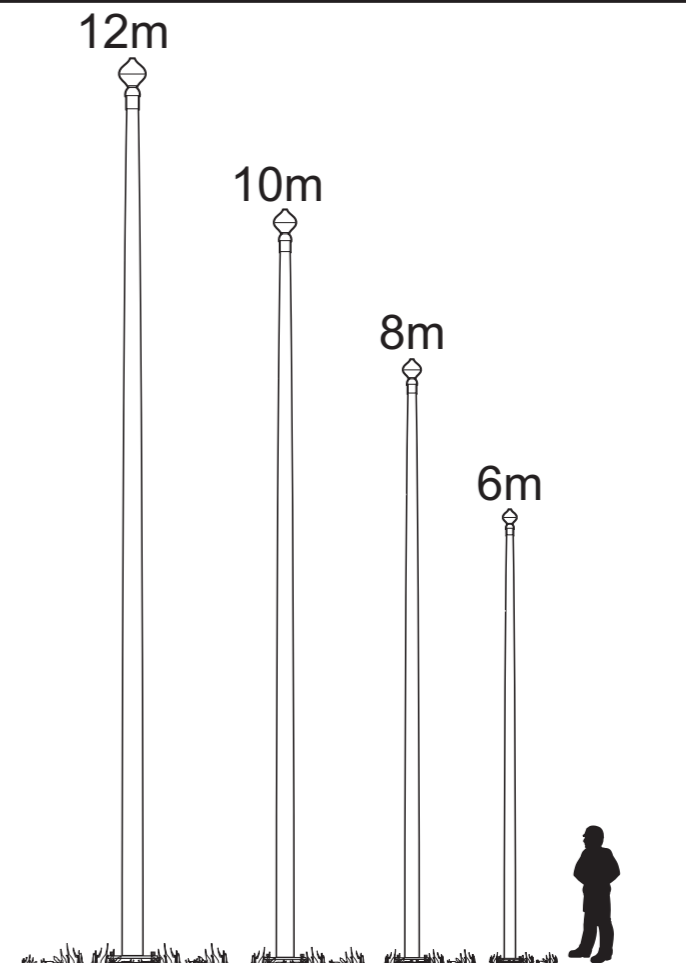

6-8 m:
90 cm
9-10 m:
110cm
11-12 m:
130 cm

6-8 m: 50x50 cm
9-10 m: 60x60 cm
11-12 m: 70x70 cm

Detalii tehnice:

Lungime	5 m	6 m	7 m	8 m	9 m	10 m	12 m
Greutate	7 kg	8 kg	11 kg	14 kg	21 kg	25 kg	29 kg
Diam. varf	50 mm	50 mm	50 mm	50 mm	50 mm	50 mm	50 mm
Diam. bazei	60 mm	60 mm	80 mm	90 mm	90 mm	100 mm	100 mm
Dimensiune recomandata pentru drapele	1x2.5m	1x3m	1.2x3m 1.2x3.5m	1x4m 1.5x4m	1x4.5m 1.5x4.5m	1.5x5m 1.5x5.5m	1.5x5.5m 1.5x6m